

CM2 : 60A40□

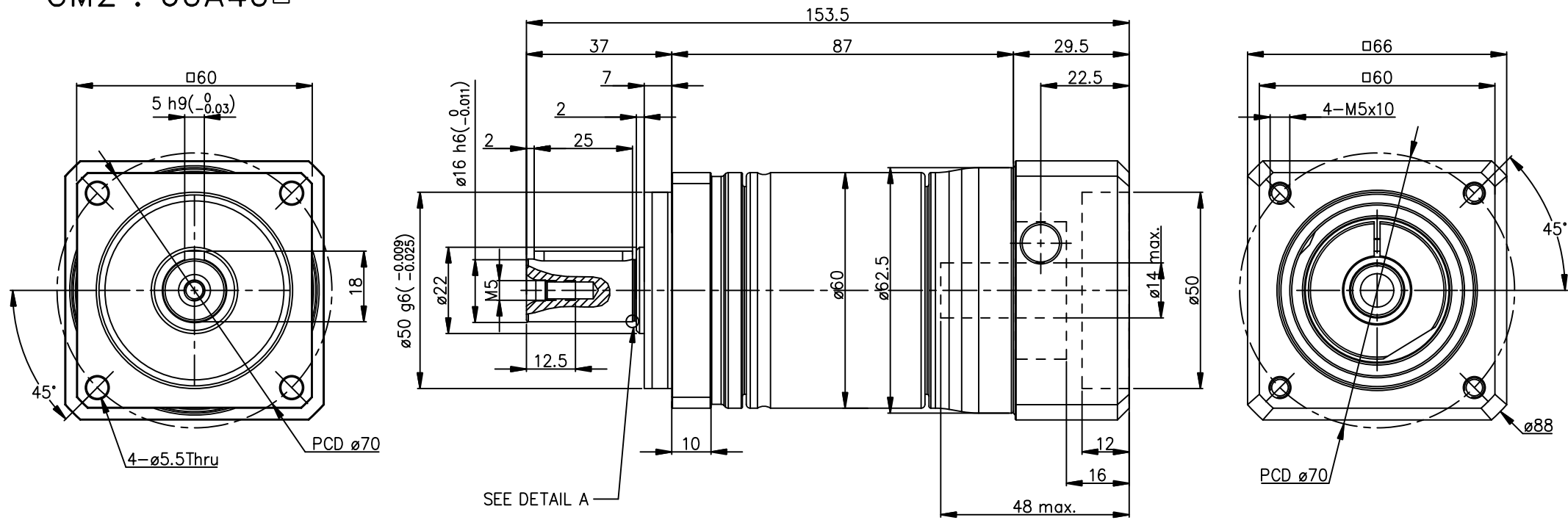

NOTE :
 SHAFT OPTION S1: SMOOTH OUTPUT SHAFT(STANDARD)
 SHAFT OPTION S2: OUTPUT SHAFT WITH KEYWAY

CM No.#	Conjunction Plate	Applicability By Ratio										Dimension [Unit : mm]											
		15	16	20	25	30	35	40	50	70	81	100	C1	C2	C3	C4	C5	C6	C7	C8	C9	C10	X1
CM1	11L30□											63	4-M4x9	8 max	30	40	4		18	135.5	11	4.5	74
	11S30□	-	-	-	-	-	-	-	-	-	-												
	17L30□																						
	17S30□																						
	23L20□																						
CM2	23S30□											66.675	4-M5x10	8 max	33	38.1	6		21	138.5	14	7.5	77
	56B10□																						
	56B20□																						
	60A10□																						
	60A20□																						
60A40□																							

Date	2015.01.08	Title	Cool Muscle Gear 2-stage
Scale	1 : 1		CM-PA2060
Size	A2	Dwg No.	CMPA20602-10
3RD Angle Projection			MUSCLE CO., LTD.