

CM2 : 60A40□

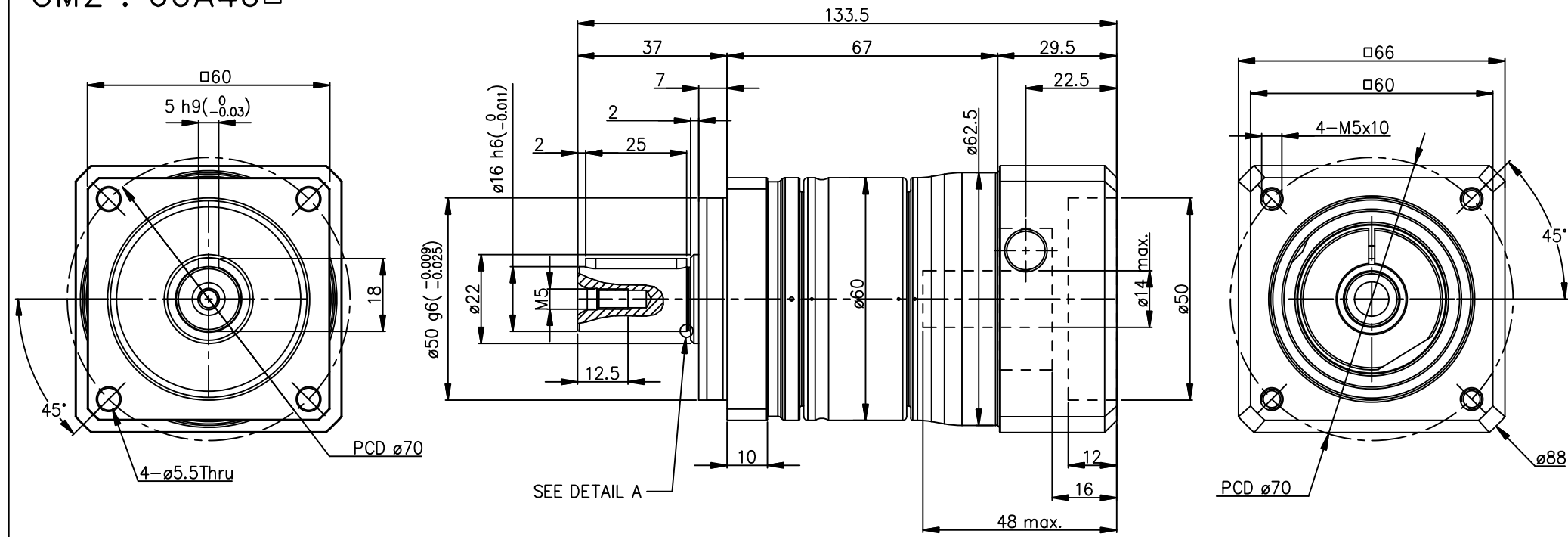

NOTE :  
 SHAFT OPTION S1: SMOOTH OUTPUT SHAFT(STANDARD)  
 SHAFT OPTION S2: OUTPUT SHAFT WITH KEYWAY

CM No.#	Conjunction Plate	Applicability By Ratio						Dimension [Unit : mm]													
		3	4	5	7	9	10	C1	C2	C3	C4	C5	C6	C7	C8	C9	C10	X1	X2		
CM1	11L30□							63	4-M4x9	8 max	30	40	4	58	18	115.5	11	4.5	74		
	11S30□	-	-	-	-	-	33				38.1	6	21		118.5	14	7.5	77			
	17L30□																				
	17S30□																				
	23L20□																				
CM2	23S30□						70	4-M5x10		30	50	4	60	18	115.5	11	4.5	80			
	56B10□																				
	56B20□																				
	60A10□																				
	60A20□																				
	60A40□																				

Date	2015.01.08	Title	Cool Muscle Gear 1-stage
Scale	1 : 1		CM-PA2060
Size	A2	Dwg No.	CMPA20601-10
3RD Angle Projection			MUSCLE CO., LTD.